

SLAB-EDGE® MODEL 3801

CORTERRA®
ADA/OBC COMPLIANT
WASH BASIN



TABLE OF CONTENTS

Prior to Installation	2
Accessibility Comparison	3
Dimensional Data	4
Rough-Ins	5
Installation	6 - 12
Finished Layouts	13
Troubleshooting	14 - 15
Cleaning and Maintenance	16
Components & Repair Parts	17 - 18

REQUIRED ITEMS FOR INSTALLATION - NOT SUPPLIED

- ✂ Chalk Line
- ✂ Hammer
- ✂ Carpenters Level
- ✂ 1/2" NPS Supply Angle Stops
- ✂ 7/16" Hex Wrench
- ✂ Plumbers Putty
- ✂ Teflon Tape
- ✂ 9/16" (8 Count) Fixture Wall Anchors and Anchoring Hardware (and Appropriate Tools)
- ✂ 9/32" (10 Count) Fixture Wall Anchors and Anchoring Hardware (and Appropriate Tools)

NEO-METRO® by ACORN®
Acorn Engineering Company
15125 Proctor Ave. • City of Industry, CA 91746 USA
TF 800.488.8999 • PH 626.336.4561 • FX 626.961.2200



Important: Some options may slightly alter installation. To ensure proper installation review the manual thoroughly and verify rough-ins before beginning any work. File this manual with the owner or maintenance personnel upon completion of installation.

Industry standard wall backing, for wall hung fixtures, is required. Installer provided wall anchors and wall anchoring hardware must be appropriate for wall construction, and have a minimum pull-out rating of 1000 lbs. (453.6 kg).

ANSI, UFAS or ADA compliance is subject to the interpretation and requirements of the local code authority and is the responsibility of the installer for verification.

Single Temp Valve Assembly: Recommended working water pressure is 30 PSI (2.07 bars) minimum to 100 PSI (6.89 bars) maximum. Maximum temperature is 130°F (54.4°C). Maximum outlet temperature is recommended is 105°F (40.6°C). Valve assembly must be drained prior to being subjected to freezing temperatures. A checkstop is provided with this valve assembly.

T/P Mixing Valve Assembly: Recommended working water pressure is 30 PSI (2.07 bars) minimum to 100 PSI (6.89 bars) maximum. Maximum hot water temperature is 180°F (82°C). Temperature adjustment range is 95°F-110°F (43°C-48°C). Valve assembly must be drained prior to being subjected to freezing temperatures. The valve assembly has a check integral to the inlet however, angle stop is to be provided by the installer.

Prior to installation, supply lines must be flushed of all foreign material such as pipe dope, chips, or solder. Debris or foreign material in water supply may damage valve.

Teflon tape is recommended on all threaded waste and supply connections to reduce the possibility of leaks.

Provide: 110-120 VAC/60Hz/3A (MAX) electrical receptacle for factory supplied 120VAC/9VDC, 100mA plug-in transformer when -SO and -SOS options are selected.

Provide: 110-120 VAC/60Hz/15A dedicated circuit when Dyson Air Blade Faucet selected. Refer to Dyson installation instructions for more information.

NOTE: Receptacle(s) must be wired to a GFCI protected circuit. Fixture must be earth grounded per N.E.C. (National Electrical Code).

ACCESSIBILITY COMPARISONS

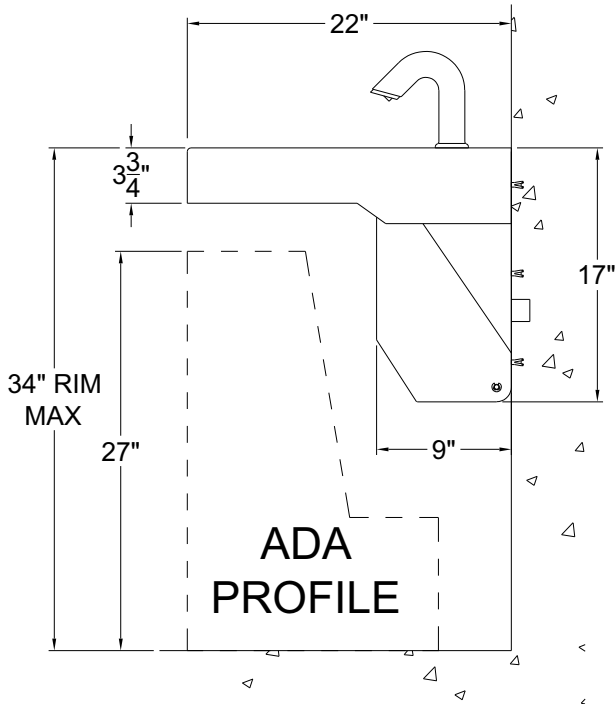

**ADA
Adult**

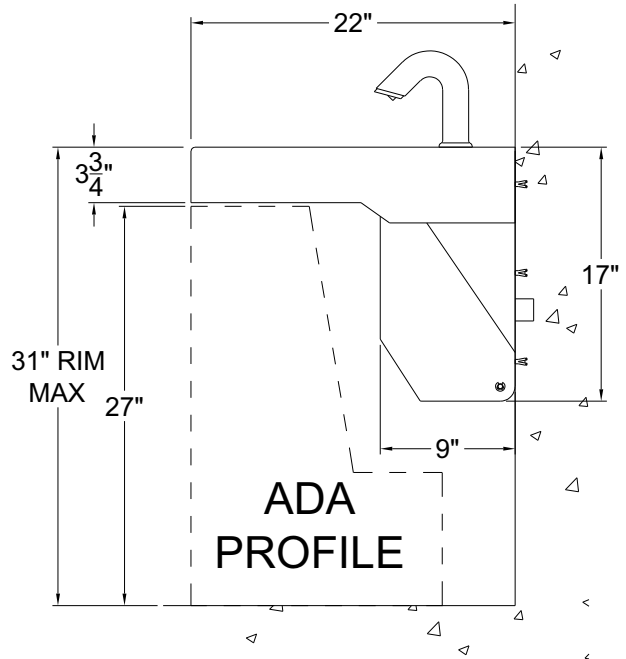

**ADA ages
6 thru 12**

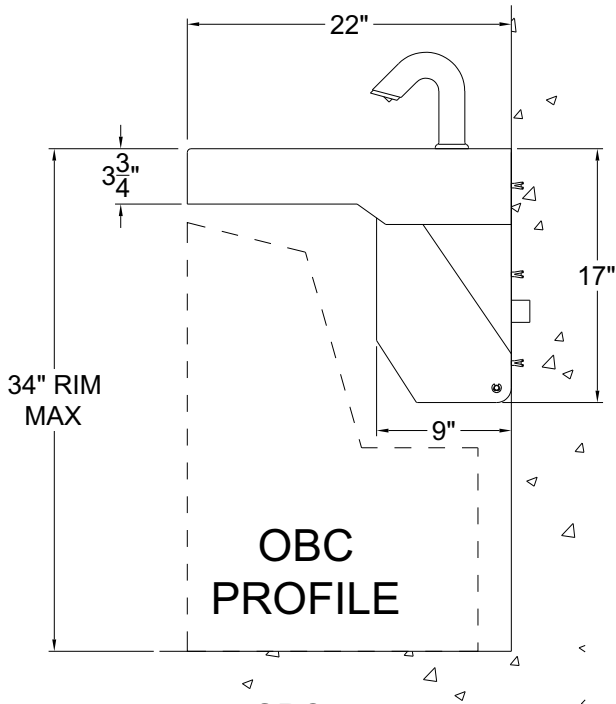

**OBC
(Ontario Building Code)**

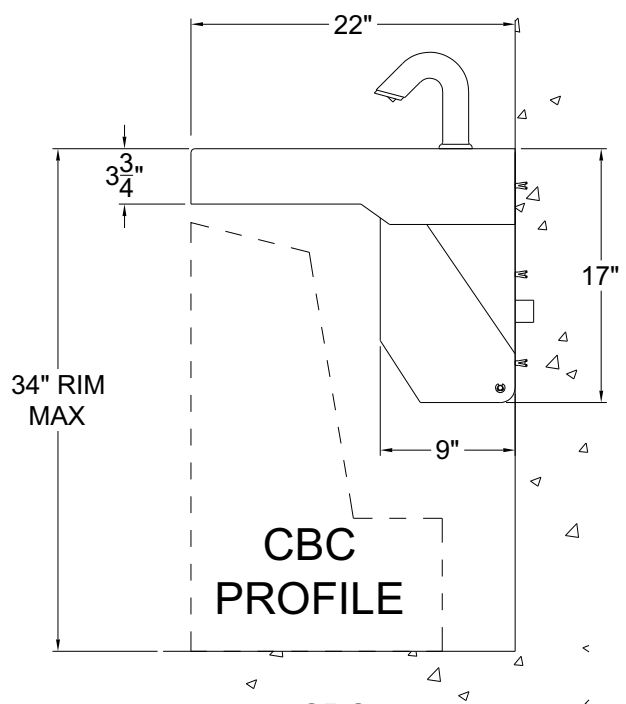

**CBC
(California Building Code)**

DIMENSIONAL DATA

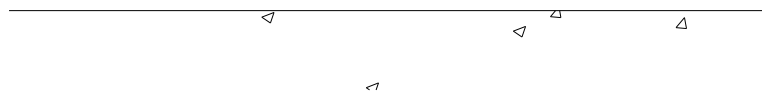
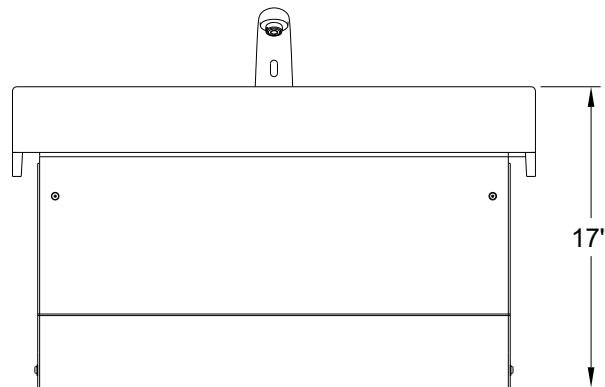
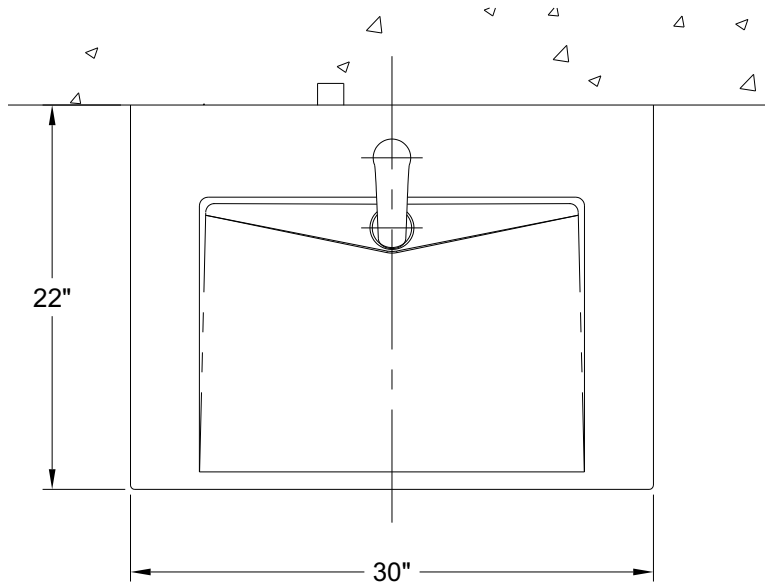

ROUGH-IN DIMENSIONS

PLUMBING

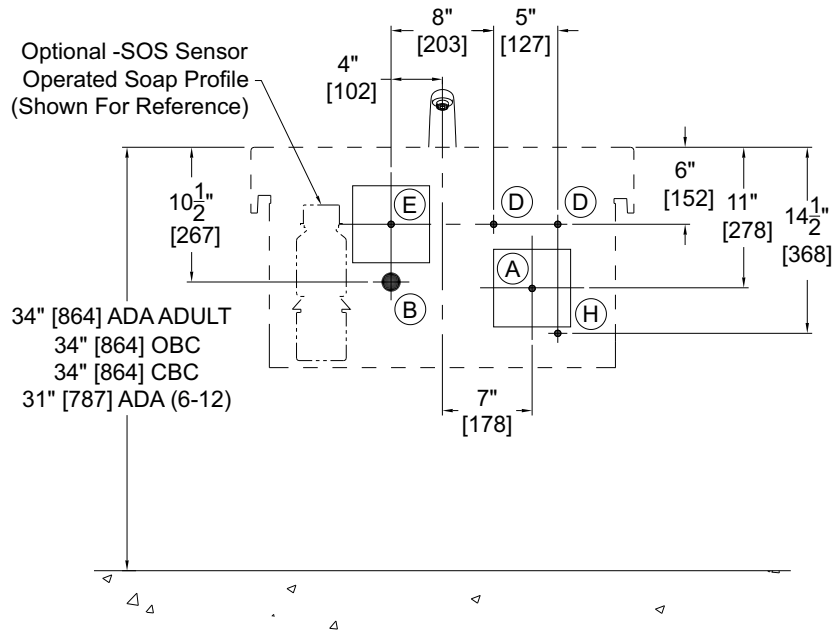

MOUNTING

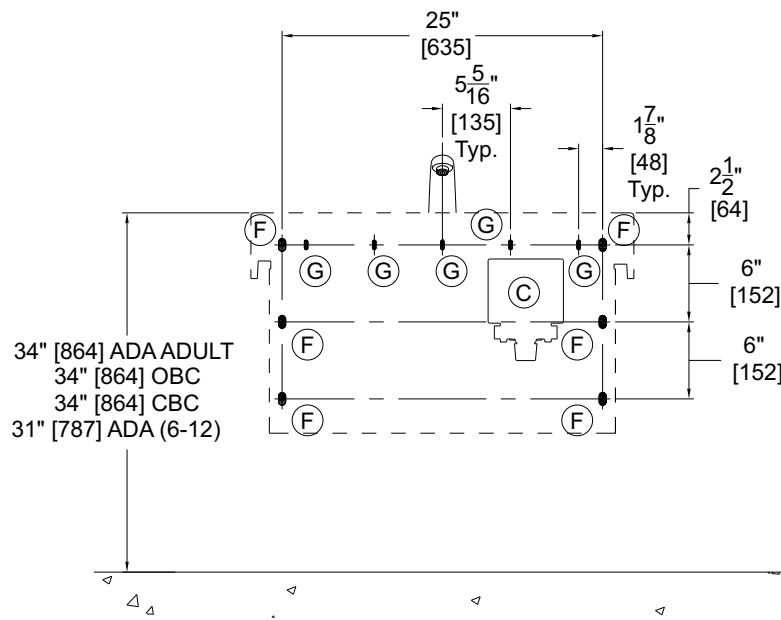

- (A) - 110-120 VAC/60Hz/15A dedicated circuit when Dyson Air Blade Faucet selected
- (B) - Waste Outlet for 1-1/2" O.D. P-Trap by others
- (C) - Valve Mounting Area
- (D) - Supply Stub-Outs with Stops for Valve 1/2" NPT Hot & Cold Supply Inlets
- (E) - 120VAC, 60 Hz, 3A (Max.) GFCI Protected, Electrical Receptacle when -SO and -SOS options are selected
- (F) - Wall Anchoring Ø9/16" x 1" Long, Angle Bracket Mounting Slots, 6 Places
- (G) - Wall Anchoring Ø9/32" x 3/4" Long, Enclosure Mounting Slots, 5 Places
- (H) - Supply Stub-Out with Stop for Valve 1/2" NPSM Tempered Supply Inlet for -SO Faucet option

OPTIONAL -MC MOUNTING CARRIER

Note: Adequate wall depth is the responsibility of Contractor/Architect. Minimum 6" stud wall required to conceal optional -MC Mounting Carrier plus consideration for fixture Water Supply and Waste Piping.

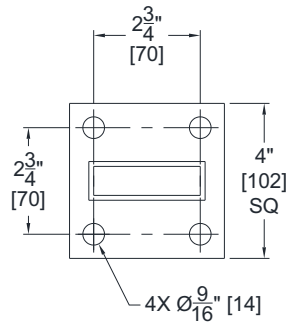

BASE DETAIL

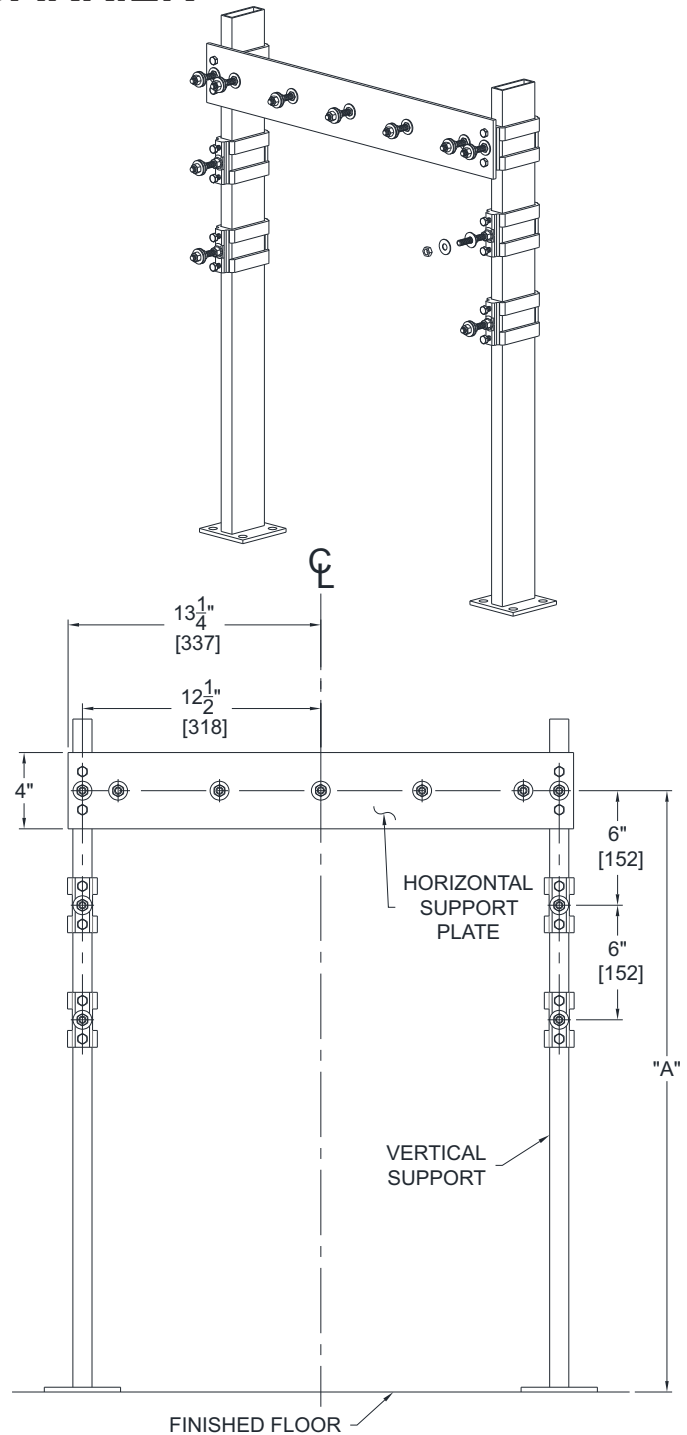
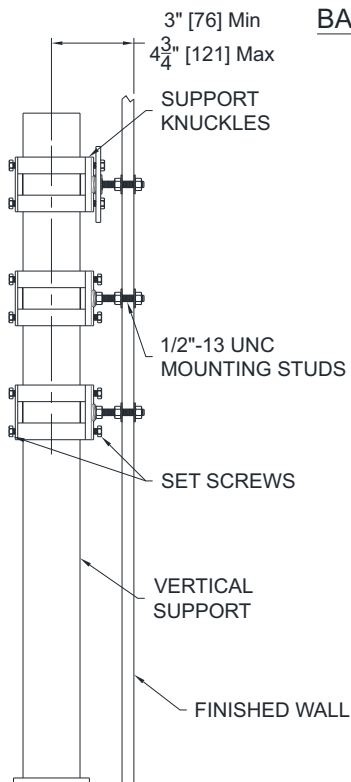

CARRIER DIMENSION INFORMATION

NOTES:

"A" - REFER TO MOUNTING ROUGH-IN FOR DIMENSION AND ADJUSTMENT CARRIER HEIGHT TO SUIT REQUIRED BASIN RIM HEIGHT.

FIXTURE ANCHORING

NOTE: FIXTURE WEIGHT IS 69 LBS.

- 1** Locate and mount the mounting bracket to a finished wall.
Locate and install P-Trap enclosure anchors provide by others.

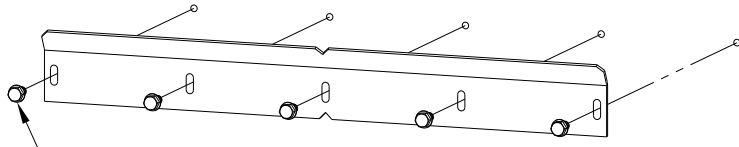

1/4" MOUNTING BOLTS
(PROVIDED BY OTHERS)

1/4"-20 UNC X 1/2" HEX
HEAD CAP SCREW
(PROVIDED)

NOTE: It may be advantageous to install to the deck, faucets, soap dispensers or other accessories prior to wall mounting.

IMPORTANT: Industry standard wall backing for wall hung fixtures is required. Installer provided wall anchors and wall anchoring hardware must be appropriate for wall construction and have a minimum pull-out rating of 1000lbs (454kg).

- 2** Assemble deck to P-Trap enclosure using the 1/4"-20 hardware provided. (6 places)

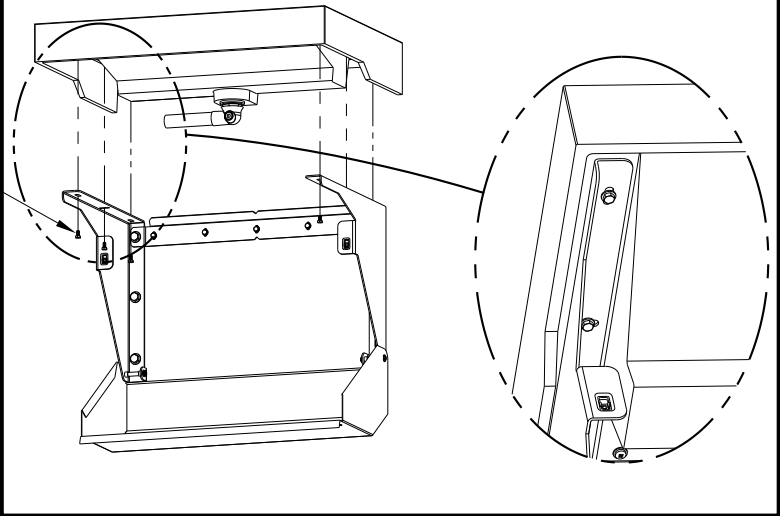

- 3** Hang deck and P-Trap enclosure onto mounting bracket, level and mount to the finished wall using 1/2" mounting hardware supplied by others.

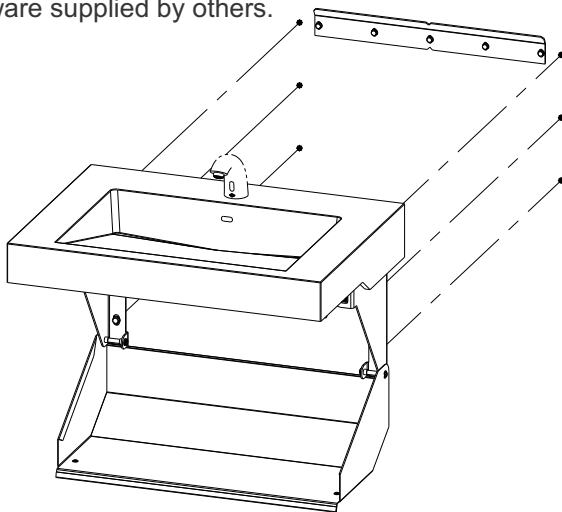

WASTE PLUMBING

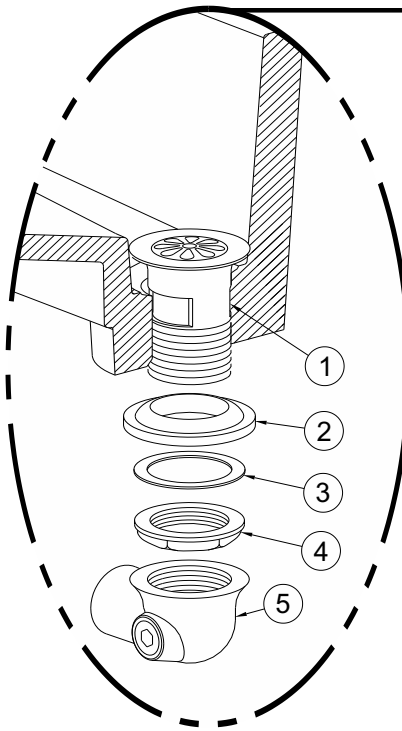

- 4** Install grid strainer and close elbow to basin bowl using plumber's putty.
1. Grid Strainer w/ 1-1/2" -16 UNE Threads
 2. Rubber Gasket
 3. Flat Fiber Washer
 4. 1-1/2" -16 UNI Rough Chrome Brass Jam Nut
 5. 1-1/2"-16 x 1-1/4" UNI Close Ell with 3/8" NPT Clean-Out Plug

NOTE: ADD TEFLON TAPE TO ITEM (1) BEFORE ASSEMBLING ITEM (5)

- 5** Assemble waste piping using teflon tape on all threaded connections and make up waste connections to 1-1/2" P-Trap

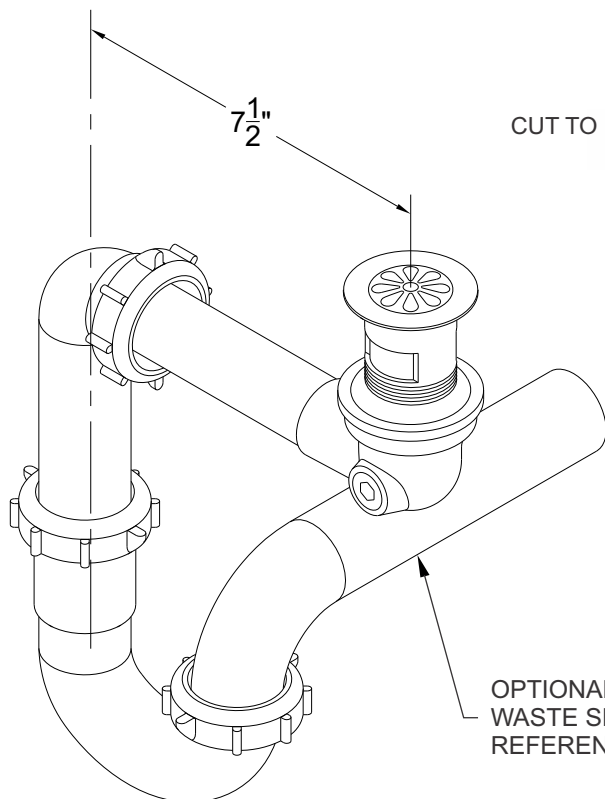
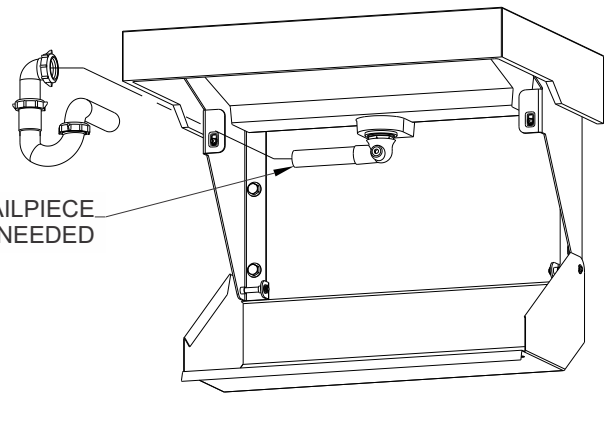

HINT: Teflon tape is recommended on all threaded waste and supply connections.

SPOUT INSTALLATION

1. Assemble spout to deck securing it with nut.
2. Connect 1/4" O.D. PE tubing from valve to Union Push-In Connection.

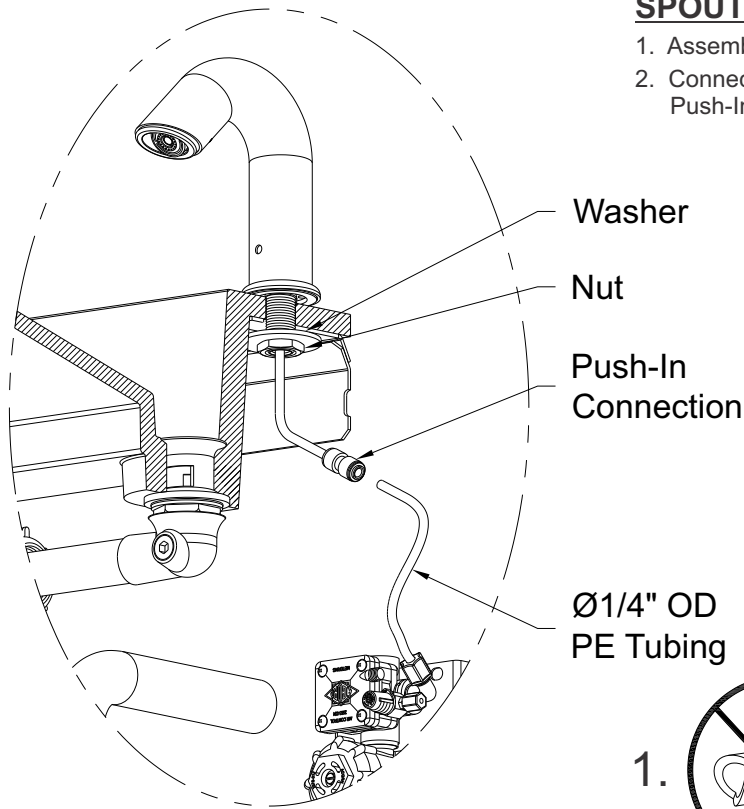

PUSH-IN FITTING INSTALLATION

NOTE: FITTINGS AND TUBE SHOULD BE KEPT CLEAN, BAGGED AND UNDAMAGED PRIOR TO INSTALLATION.

1. Cut to fit length of 1/4" PE tubing and remove any burrs or sharp edges. Ensure that the outside diameter is free from score marks. Tube ends should be square.
2. Firmly and fully insert the tubing end into the push-in fitting up to the tube stop located approximately 1/2" deep.
3. Pull on the fitted tubing to ensure it is secure. Tube should not come free from the fitting. Water test the connection assembly prior to leaving the site to ensure there are no leaks.
4. To disconnect the tube from the fitting ensure that the water line is depressurized. Push collet square towards the push-in fitting body and hold. While holding the collet in, pull on the PE tubing to remove from the push-in fitting.

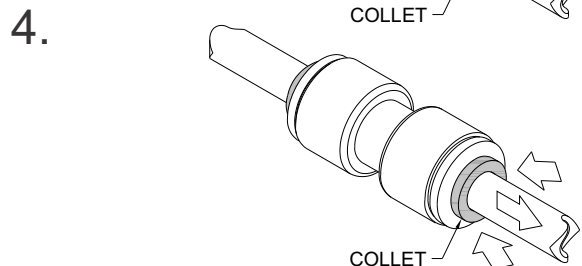
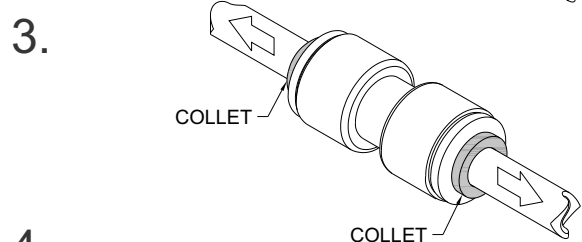
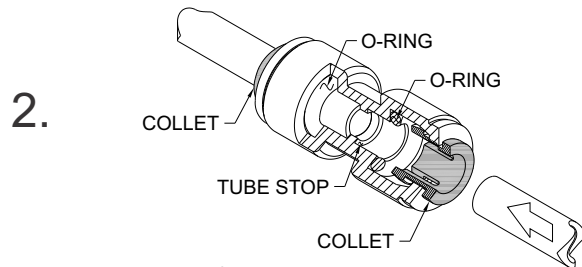
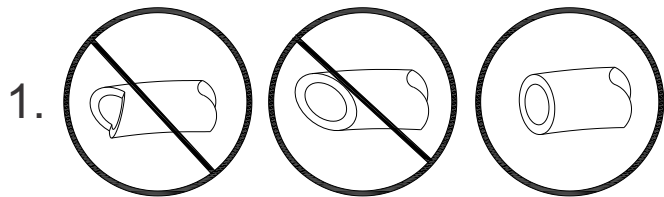

VALVE INSTALLATION & ADJUSTMENT

Valve Assembly Installation:

NOTE: Installation should be in accordance with accepted plumbing practices.

- 1) Locate suitable place for mounting the valve assembly. Valve assembly should be accessible for service and adjustment and as close to the point-of-use as possible. Wall anchors and anchoring hardware are by others.
- 2) Connect hot and cold water to supply valve using 1/2" NPTE connections by others.
- 3) Connect outlet of tempering valve to spout using 1/2" NPT connections provided (Refer to pg.8).
- 4) Turn on hot and cold water supplies. If any leaks are observed, hand-tighten connections as necessary to stop leaks before proceeding.
- 5) Turn on fixture and allow water to flow for 2 minutes. Measure water temperature at outlet. If water is not at desired temperature, adjust as necessary.



HINT: Angle stops are recommended and is the responsibility of the installer.

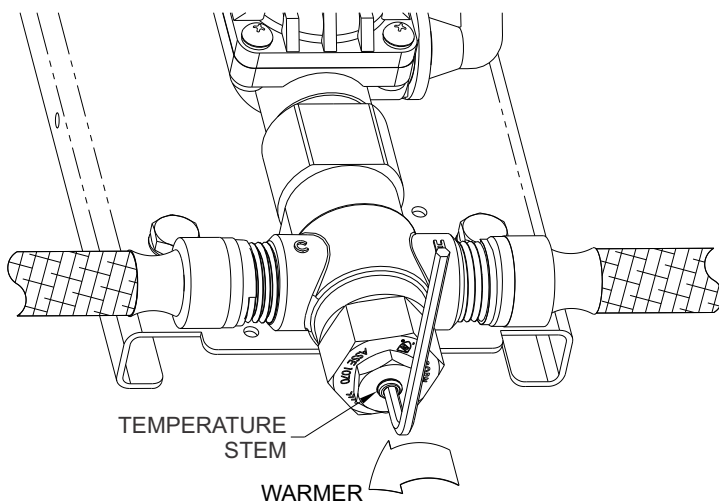

IMPORTANT

Flush supply lines of all foreign material such as pipe dope, pipe chips, solder, sand etc. before making up supply connections.

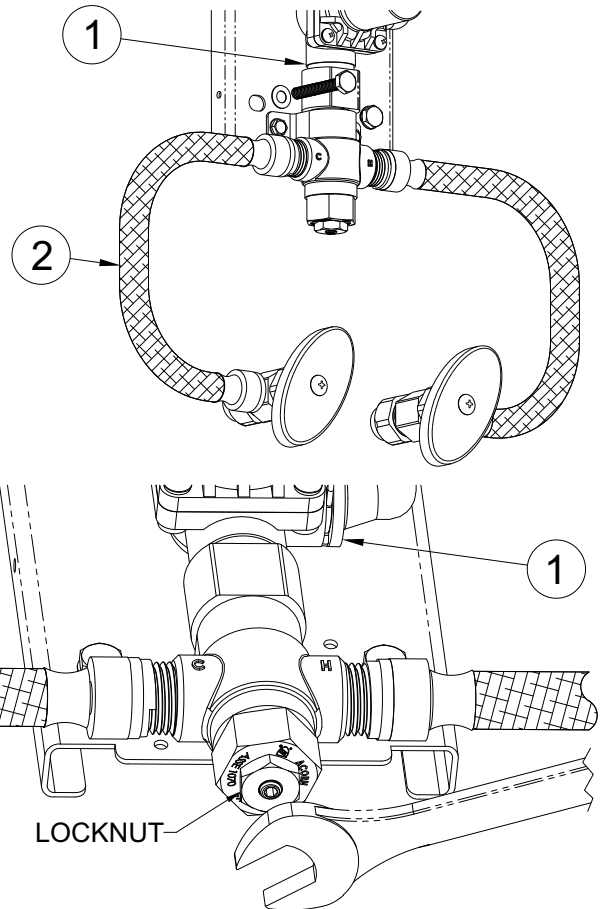

Temperature Adjustment

(For -MXTP Option):

- 1) Loosen locknut.
- 2) Turn on fixture and run water for at least 2 minutes. Allow supply temperature to stabilize.
- 3) Turn temperature stem counter-clockwise for hotter or clockwise for colder outlet temperature.
- 4) Tighten locknut to prevent accidental or unauthorized temperature adjustment.
- 5) Re-check outlet temperature.

HAND OPERATION & CONNECTIONS

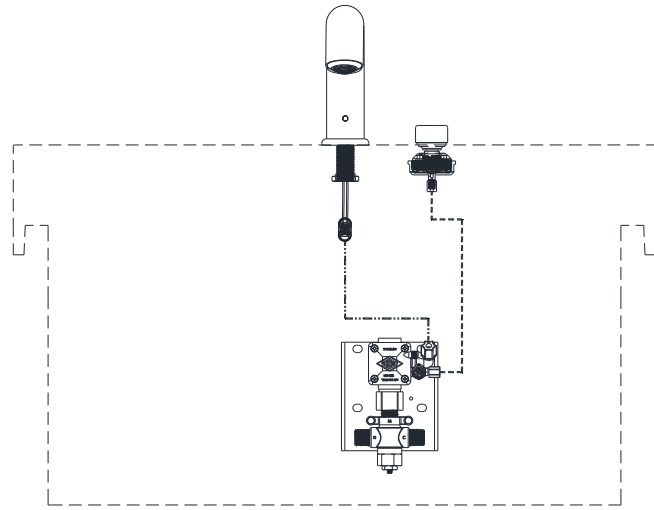

3801-H-MXTP DIAGRAM (SHOWN FOR REFERENCE)

----- 1/8" O.D. AIR TUBE
 - - - - - 1/4" O.D. WATER LINE

Ferrule Nut
 Timing Screw
 To adjust timing, turn timing screw.

! IMPORTANT
 Do not over tighten ferrule nuts.

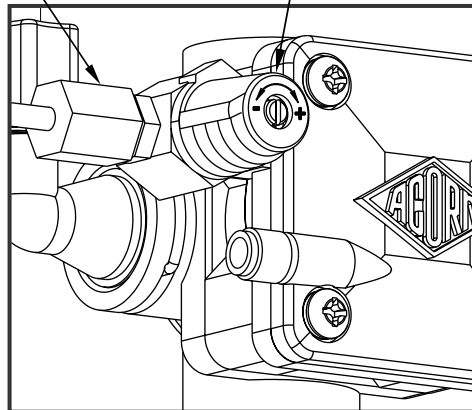
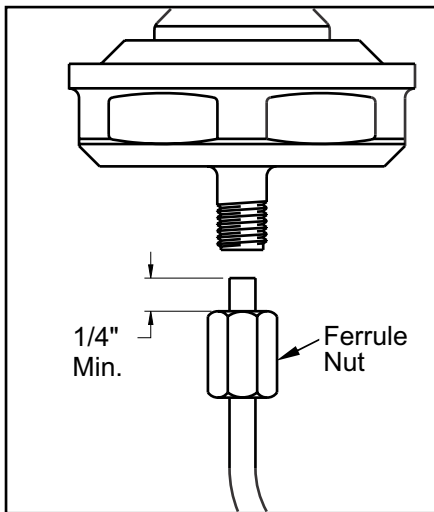

💡 Turn timing screw clockwise to increase timing.

! IMPORTANT
 Leave a minimum 1/4" of polyethylene tubing through the Ferrule Nut on the pushbutton assembly. This is necessary to ensure proper tubing connection.

OPTIONAL ACCESSORY INSTALLATION & ASSEMBLY

WARNING

Some soaps contain corrosive additives that can cause rust in soap dispensers. Acorn Engineering Company recommends user/ maintenance personnel review MSDS reports of soap and possible corrosive additives noted.

A. Install soap reservoir to wall inside P-Trap enclosure using mounting brackets provided as shown. Wall anchors and anchoring hardware provided by installer.

B. Install soap filler assembly to deck as shown.

C. Attach 1-1/4" O.D. refill tube to soap filler assembly and soap reservoir with provided hose clamps.

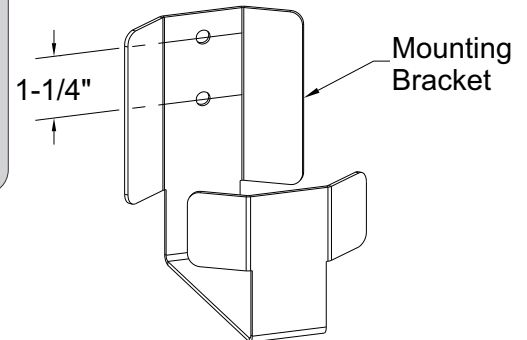
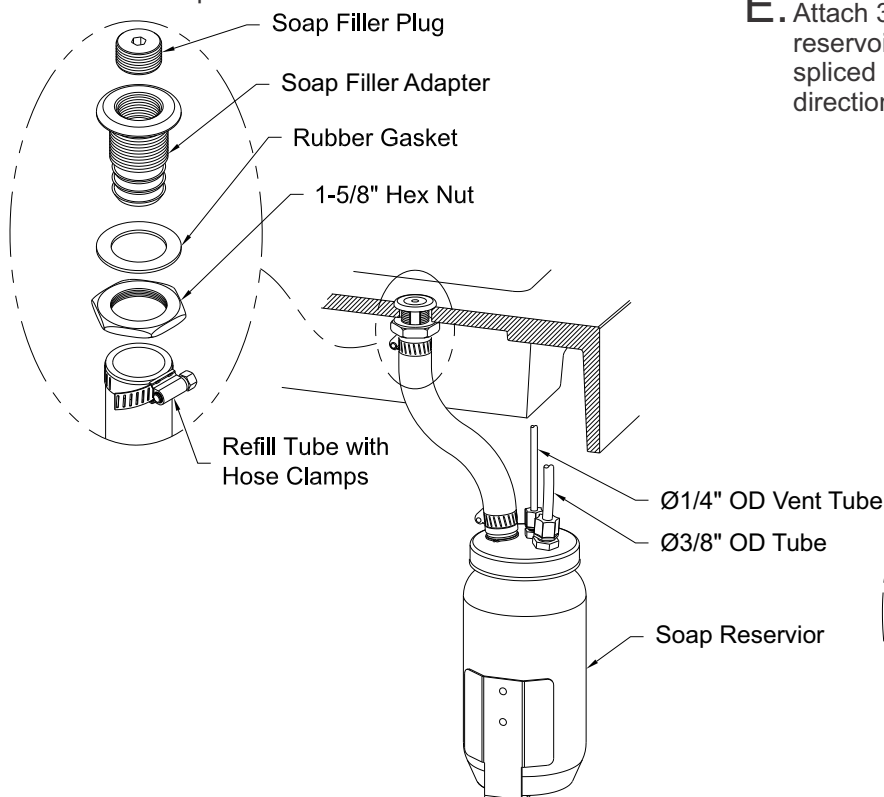

D. Install soap dispenser(s) onto deck. NOTE: Gasket and Washer are located beneath the deck.

E. Attach 3/8" O.D. Tubing to the dispenser(s) and reservoir. NOTE: Check Valve must be field spliced into tubing and installed with respect to direction of flow.

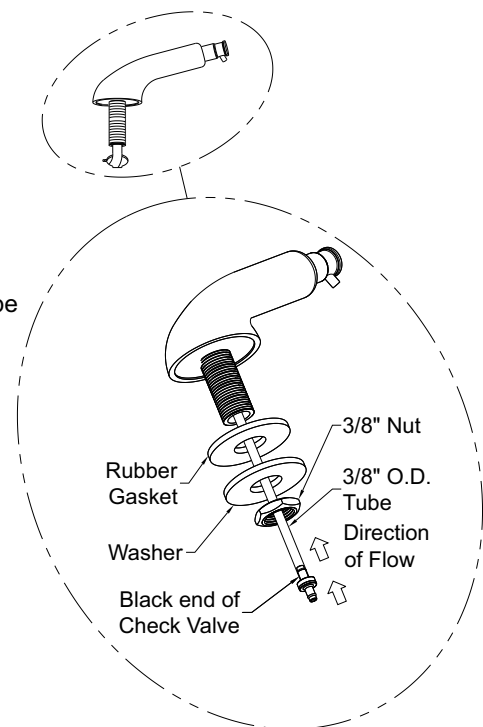

 **HINT:** For best results install soap reservoir fill hole directly below soap filler on deck with refill tube as short and straight as possible to facilitate refill of soap without backup or overflow.

FINISHED LAYOUTS
(SHOWN FOR REFERENCE)

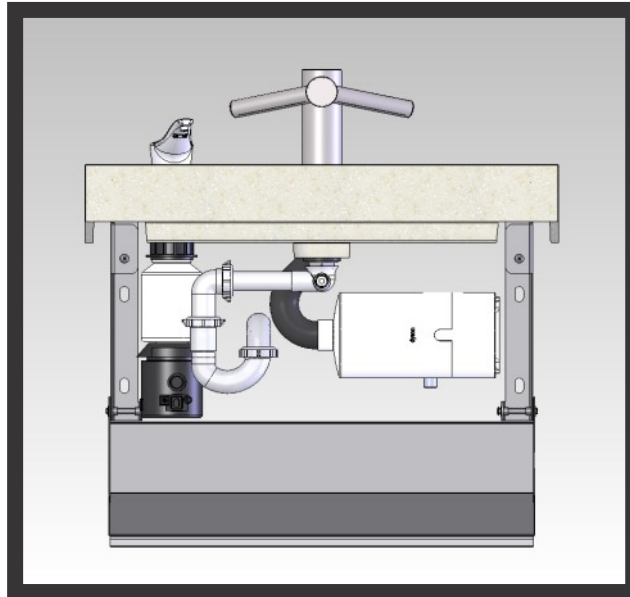



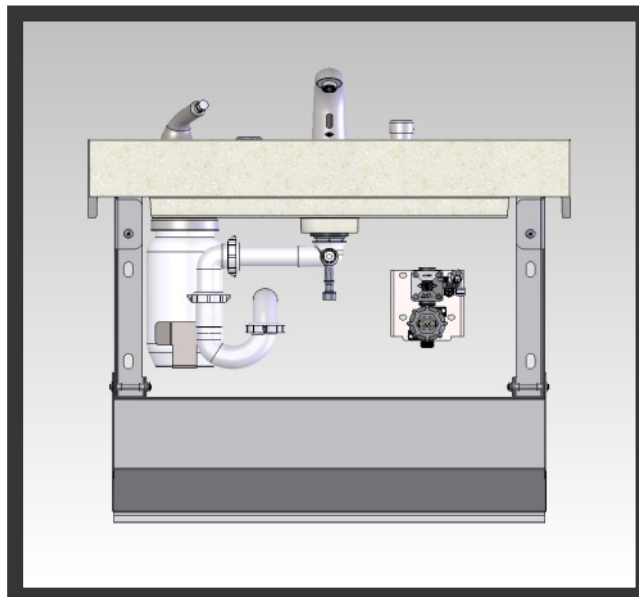

MODEL #3801-WD04-SOS

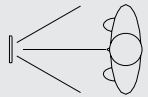

MODEL #3801-H-PDM

TROUBLE SHOOTING FOR 9 VOLT DC SENSOR OPERATED VALVES

Normal Valve Function: 9 Volt DC sensor operated valve has flow time of 90 seconds maximum. To reactivate, the user must move out of and return to the sensing area.		
CONDITION: WATER DOES NOT FLOW  		
<i>Indicators</i>	<i>Probable Cause</i>	<i>Solution</i>
Sensor flashes continuously every 2 seconds when hands are within range.	Low battery warning	Replace battery
Sensor does not flash when the user's hands are within range.	Circuit breaker tripped.	Reset circuit breaker
	Battery completely used up.	Replace battery
	Defective 9V DC transformer	Replace transformer.
	Transformer polarity crossed	Replace transformer (sensor may be damaged and need replacement).
	Unit is in "Security Mode" after 90 seconds of constant detection.	Remove sources of detection and wait 30 seconds before checking.
	Range is too short.	Increase range.
	Range is too long.	Decrease range and wait 30 seconds.
	Sensor is picking up a highly reflective surface.	Eliminate cause of reflection and wait 30 seconds before checking.
Sensor flashes once when user's hands are within range.	Stops or water main closed.	Open stops or water main.
	Bad sensor to solenoid connection.	Ensure wires make proper contact.
	Debris or scale in solenoid assembly.	Remove solenoid, pull out plunger and spring, and clean with scale remover solution or pressurized air.
	Debris or scale in diaphragm.	Remove diaphragm and clean
	Debris or scale in strainer.	Remove strainer and clean.
CONDITION: FALSE TRIGGERING; WATER FLOWS CONTINUOUSLY 		
<i>Indicators</i>	<i>Probable Cause</i>	<i>Solution</i>
Sensor flashes when user's hands are within range.	Debris or scale in diaphragm	Remove diaphragm and clean.
	Diaphragm is defective or torn.	Replace diaphragm.
Sensor does not flash when users hands are within range.	Sensor is dirty or covered.	Clean or uncover sensor and wait 30 seconds.
	Range too long or highly reflective surface, sunlight, bright lights etc. are triggering sensor.	Decrease range and wait 30 seconds. Eliminate cause of reflection or correct lighting problem.
CONDITION: WATER FLOWS CONTINUOUSLY BUT STOPS WHEN HANDS ARE WITHIN RANGE  		
<i>Indicators</i>	<i>Probable Cause</i>	<i>Solution</i>
Water runs continuously when sensor not activated. Sensor flashes when hands are within range and water shuts off.	Solenoid polarity crossed.	Disconnect solenoid and reverse polarity.

TROUBLE SHOOTING FOR OPTIONAL PUSHBUTTON OPERATED VALVES

Normal Valve Function: Hand pushbutton operated valve has an adjustable flow time from 5 to 60 seconds.

CONDITION: WATER DOES NOT FLOW

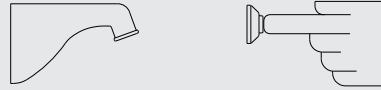

<i>Probable Cause</i>	<i>Solution</i>
Water main closed.	Open water main.
Checkstops closed.	Open checkstops.
Debris or scale in checkstop strainer	Remove checkstop strainer and clean.
Air leaks from 1/8" O.D. tubing or fittings.	Replace damaged tubing or fitting.
Pushbutton air diaphragm leaks.	Replace pushbutton air diaphragm.
Servomotor diaphragm center hole is blocked.	Remove blockage.
Servomotor upper diaphragm is damaged.	Replace servomotor upper diaphragm.
Low or no water pressure at supplies.	Increase water pressure to 30 PSI minimum.

CONDITION: WATER DRIPS, WON'T SHUT OFF

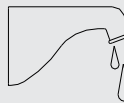

<i>Probable Cause</i>	<i>Solution</i>
Servomotor diaphragm offset hole is blocked.	Remove blockage.
Servomotor seat is damage	Replace servomotor seat.
Servomotor plate or diaphragm is obstructed.	Remove cause of obstruction.
Servomotor timer assembly is damaged.	Replace servomotor timer assembly.

CONDITION: REDUCED WATER FLOW

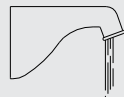

<i>Probable Cause</i>	<i>Solution</i>
Valve riser tubing is crimped.	Straighten valve riser tubing.
Debris or scale in checkstop strainer	Remove checkstop strainer and clean.
Blockage in valve flow control.	Remove blockage.
Low water pressure at supplies.	Increase water pressure to 30 PSI minimum.
Lime deposits in hot water pipes.	Remove lime deposits with appropriate cleaning solution.

CONDITION: PREMATURE WATER SHUT OFF

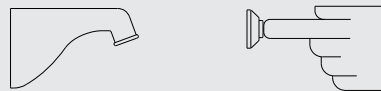

<i>Probable Cause</i>	<i>Solution</i>
Air leaks from 1/8" O.D. tubing or fittings.	Replace damaged tubing or fitting.
Pushbutton air diaphragm leaks.	Replace pushbutton air diaphragm.

CARE, CLEANING, AND REPAIR OF CORTERRA® SOLID SURFACE

CORTERRA® SOLID SURFACE

Acorn's densified solid surface material is composed of recycled solid-surface polymer resin, aluminum trihydrate and fillers. It is resistant to stains, impact and burns and complies with ANSI Z124.3. It is attractive, durable and easy to maintain.

ROUTINE CLEANING

Corterra® should be kept clean at all times. If maintained, Corterra® surfaces will retain their new, clean appearance indefinitely. Wash with a non-abrasive all purpose cleaner and water, then rinse. Wipe dry. (Never use cleaners with strong chemicals such as toilet bowl cleaners, rust removers, ceramic cook top cleaners, laquer thinners or oven cleaners). To remove persistent stains use a Scotch Brite pad and an abrasive cleaner or a solution of household bleach and water (1 part water to 1 part bleach).

REPAIRING SURFACE DAMAGE

Surface damage, such as minor chips, scratches, burn marks and graffiti can be repaired with a fine grit abrasive cleanser, such as a Scotch-Brite pad or fine grit sandpaper. For more serious physical damage caused by vandals, an Acorn Solid Surface Repair Kit is available. Contact the factory for details. Refer to drawing #9927-160-002.

SOAP SYSTEMS

Acorn soap reservoirs and dispensers provide a dependable operation over long term when proper maintenance is performed and the correct soap is being used. The most common problem with soap systems is that the wrong viscosity (thickness) of soap is being used or high acidic pH levels are in the ingredients. Soap thickness can be best explained as no thicker or thinner than normal household liquid dish soap. The pH level of the soap should be 6.5 to 8.5; more acidic soaps will corrode the metal parts and degrade rubber or plastic components.

Soap reservoirs and dispensers should be maintained periodically to clear residue. This should be done in hot water to clean the internal components. The valve should be pumped multiple times to thoroughly clean any residue inside. The reservoir and tubing should also be flushed and cleaned with hot water. In cases of extreme clogs, the dispenser should be disassembled and the parts thoroughly cleaned.

WARNING: Some soap contains corrosive additives that can cause rust on stainless steel surfaces. Acorn recommends user/ maintenance personnel review MSDS reports of soap and possible corrosive additives noted.

CARE AND CLEANING OF STAINLESS STEEL SURFACE

NORMAL CLEANING

Clean weekly or more often, as needed
(especially high polishing surfaces)

RECOMMENDED CLEANING MATERIALS

- Sponge – natural or artificial
- Nylon or other soft-bristle material brush
- Soft cloth (as used on automobile finishes)

RECOMMENDED CLEANING SOLUTIONS

- Hand dishwashing liquid/soft water solution
- Mild soap/soft water solution
- 3M Stainless Steel Cleaner/Polish
- White vinegar/soft water solution (for brightening, removing oil and hard water deposits)
- CLR Brand Cleanser or baking soda/soft water solution (for brightening, removing hard water deposits)
- Club soda and sponge

FOR HIGH POLISH STAINLESS STEEL

Note: High polish stainless steel surfaces should never come into contact with any abrasive cleaning brush, cloth or cleaning agent.

To remove smudges and fingerprints:

Wipe surfaces with a quality Stainless Steel Cleaner/Polish. Apply using a soft non-abrasive cloth, wipe surfaces with stainless steel cleaner/polish.

To remove rust stains:

Wipe surfaces with CRES (available from Acorn) or equivalent cleaner. Use recommended solutions. Apply using a soft non-abrasive sponge. Rinse surfaces immediately after application. Always follow cleaner product directions provided. Afterwards, using a soft, non-abrasive cloth, wipe surfaces with stainless steel cleaner/polish.

FOR TOUGH PROBLEMS

- CRES Cleaner specifically for rust stains (available from Acorn)
- Tarn-X for general stains
- #7 chrome polish
- Silver polish



To remove stubborn spots or to treat a scratch (Standard Satin Finish Only):

Use of synthetic, abrasive, general-purpose pads such as Scotch Brite is recommended. Apply the stainless steel cleaner/polish to the synthetic, abrasive pads and CAREFULLY rub out spot with cleaner/ polish. Be sure to rub in the direction of the grain! Do not allow steel wool to come in contact with the stainless steel. Steel particles can embed into the stainless steel surface and create rust!

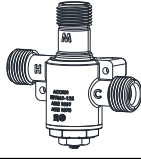
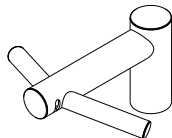

Stainless steel should be kept clean at all times. If maintained, stainless steel surfaces will retain their new, clean, polished appearance indefinitely. To remove water spots or rust spots, stainless steel cleaner/polish on a cloth is recommended.

IF SPOTS ARE STUBBORN OR IF YOU WISH TO TREAT A SCRATCH: synthetic, abrasive, general-purpose pads such as Scotch Brite are recommended. Apply the stainless steel cleaner/polish to the synthetic, abrasive pad and CAREFULLY rub out spot with cleaner/polish. **Be sure to rub in the direction of the grain!** Do not allow steel wool to come in contact with stainless steel. Steel particles can embed into the stainless steel surface and create rust.

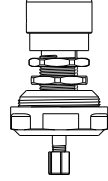
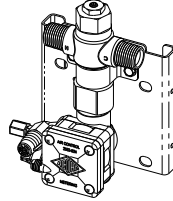
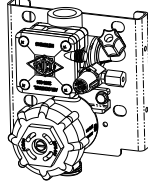
COMPONENTS & REPAIR PARTS

Description	Part No.	Diagram
-SO VALVE AND SPOUT DETAILS		
3801-SO Binho Industrial Sensor Operated Spout 9VDC provided with Power Supply and Battery Pack	2992-066-000	
3801-SO-MXTP/3801-WD04-MXTP/ 3801-H0-MXTP/3801-H1-MXTP/ 3801-H34-MXTP ST7069-12, 1/2" NPSM, Mixing Valve	7802-401-001	
-WD04 VALVE AND SPOUT DETAILS		
3801-WD04 Dyson Airblade™ Wash + Dry (Deck Mounted Short Faucet)	3040-091-000	
-H VALVE AND SPOUT DETAILS		
3801-H "J" Hand Operated Spout	2993-206-001	
Push Button Assembly	2566-270-001	
3801-H-MXTP Optional T/P 1-Station, Hand Operated, ASSE 1070, Mixing Valve Assembly	2598-201-001	
3801-H-ST Optional 1-Station, Hand Operated, Single Temp, Metering Valve Assembly	2598-301-001	

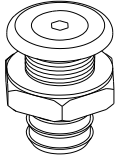
COMPONENTS & REPAIR PARTS

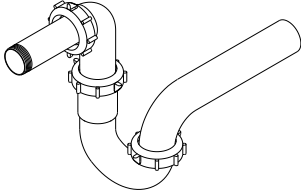
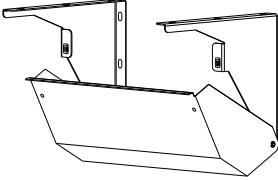
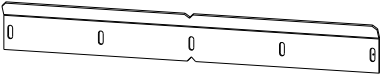
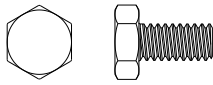
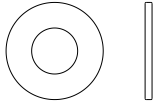
Description	Part No.	Diagram
-PDM SOAP OPTION		
Soap Filler Assembly	1391-008-001	
WASTE ASSEMBLY		
Grid Strainer w/ Close Elbow	4926-062-001	
-PT P-Trap Waste Assembly Chrome White Poly	4970-024-002 4970-040-003	
ENCLOSURES		
Trap Enclosure	6216-100-002	
MOUNTING HARDWARE		
Mounting Bracket	6216-104-199	
Stainless Steel, Hex Head, Cap Screw, 1/4"-20 x 1/2" Long	0206-004-000	
1/4"-20 x 1" Thick Fender Washer	0332-004-000	
1/4" Stainless Steel Helical Lock Washer	0337-050-000	